

A		32
B		32
C	 4,5x60 Flangeado	16
D	 4,0x25 Chata	16
E	 4,0x45 Chata	20
F	 4,0x12 Chata	20
G	 3,5x16 Chata	34
H	 4,0x12 Panela	22
I	 8x8	100
J	 8x30	56
K	 3,5x20 Chata	08
L	 ø35 Dobradiça Super Curva	06

M	 Calço Super Curva	06
N	 6,0x12	18
O	 350mm	06 Peças
P		06
Q		08
R		04
S	 1889mm	01
T		15
U		02
V	 858mm	01
W	 Calço Curva	03
X	 ø35 Dobradiça Curva	03
Y	 8x50	04

Utilizar a régua abaixo para medir os componentes.



medidas em mm

Nº Peça	Nome da Peça	Qtde
1	Tampo	01
2	Lateral Esquerda	01
3	Divisória Central	01
4	Lateral Direita	01
5	Fundo	01
6	Prateleira Fixa	02
7	Prateleira Fixa Inferior	01
8	Prateleira Móvel	02
9	Travessa Lateral Base	02
10	Pé	04
11	Frente de Gaveta	03
12	Lateral de Gaveta Direita	03
13	Fundo de Gaveta	03
14	Traseiro de Gaveta	03
15	Aplique Gaveta	03
16	Porta	03
17	Aplique Porta	03
18	Traseiro Estreito	02
19	Traseiro Largo	01
20	Travessa Fronta Base	02
21	Pé Central	02
22	Divisória Gaveta	02
23	Divisória Média	02
24	Distanciador Corrediça	04
25	Lateral de Gaveta Esquerda	03

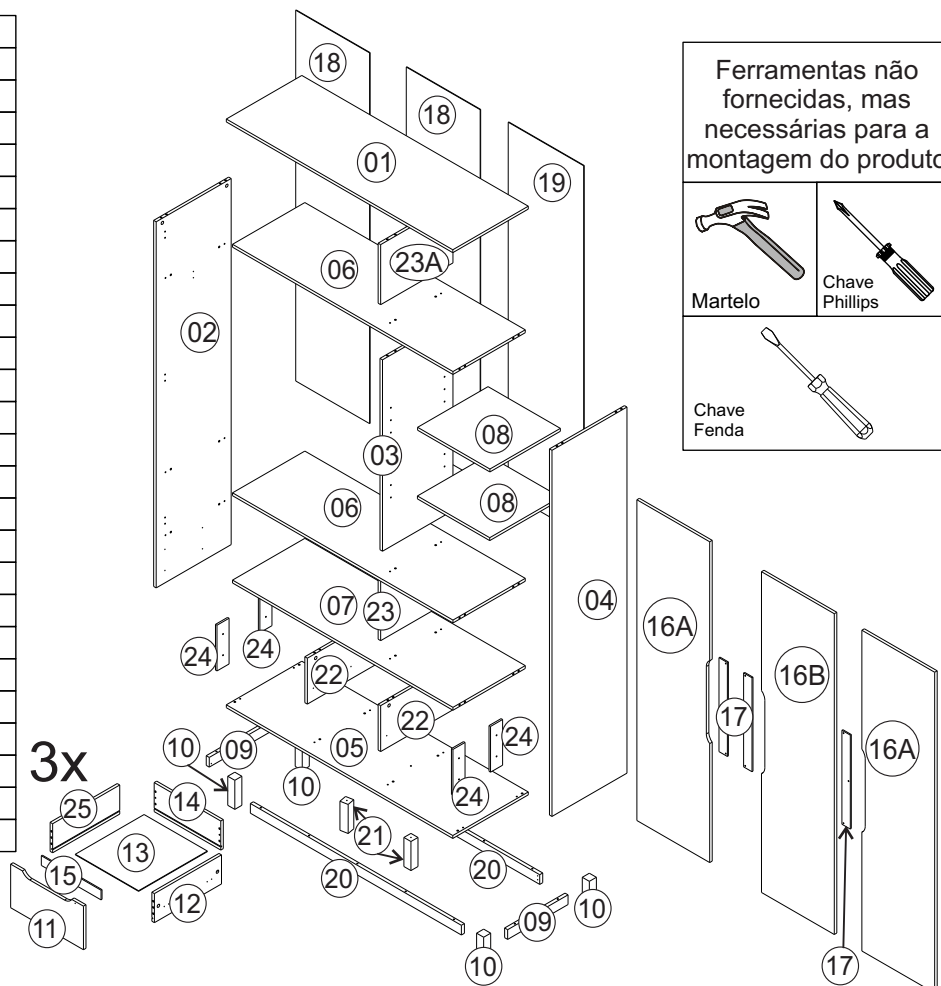

Ferramentas não fornecidas, mas necessárias para a montagem do produto



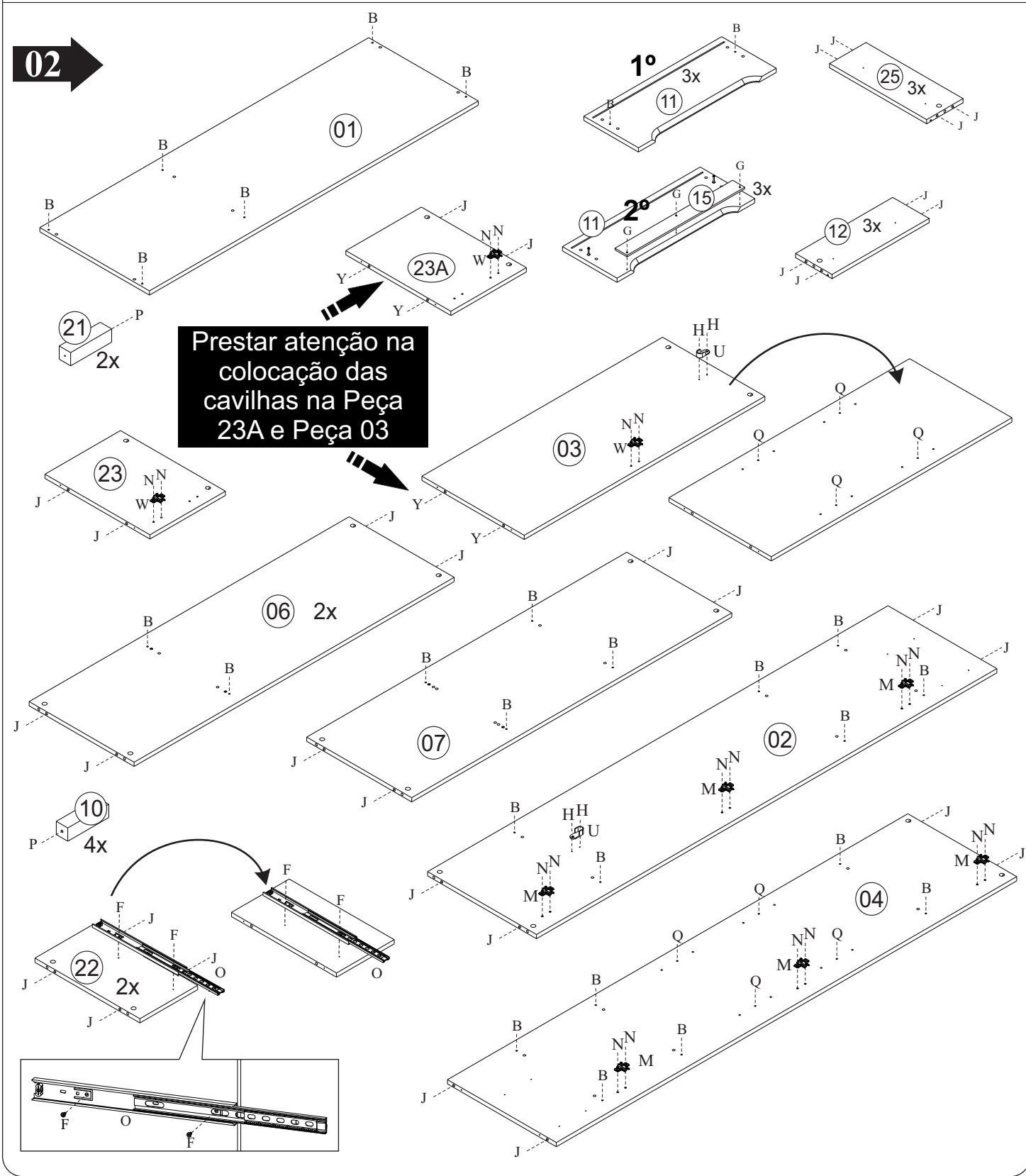
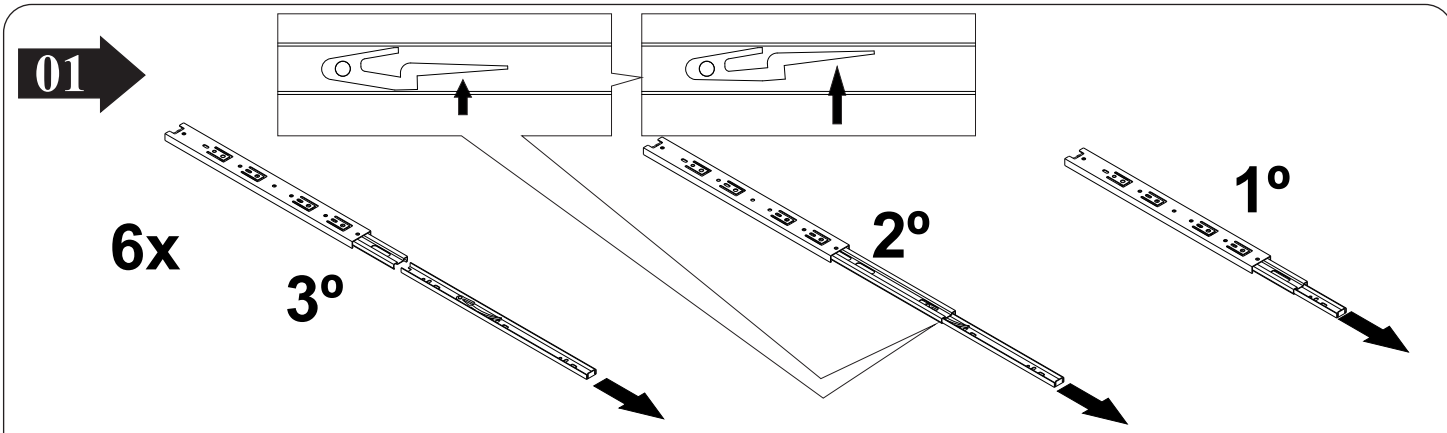

03 →

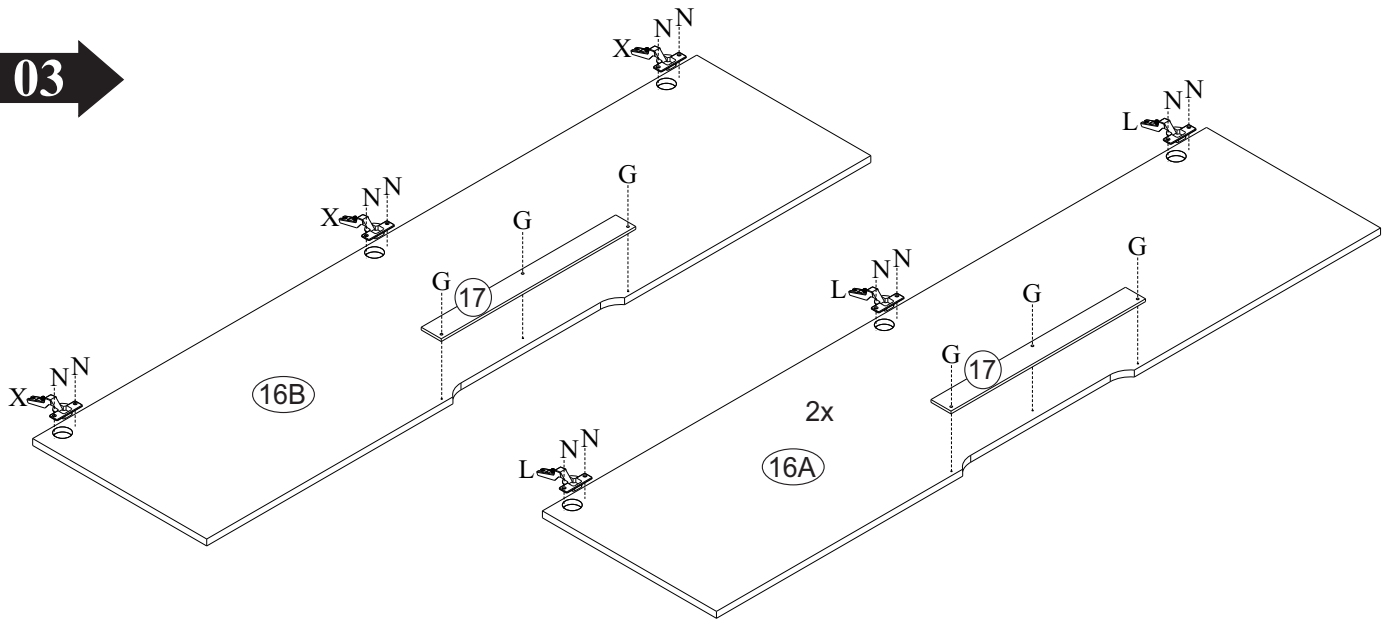

04 →

3x

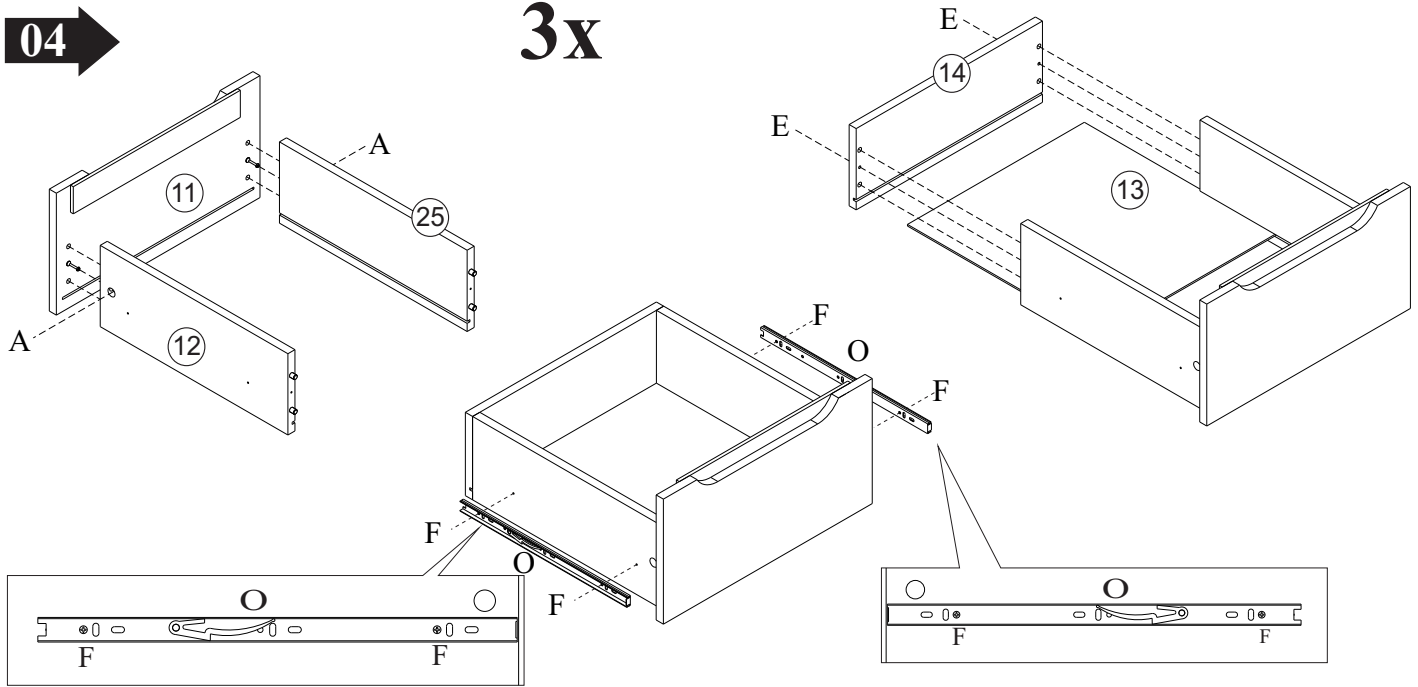

05 →

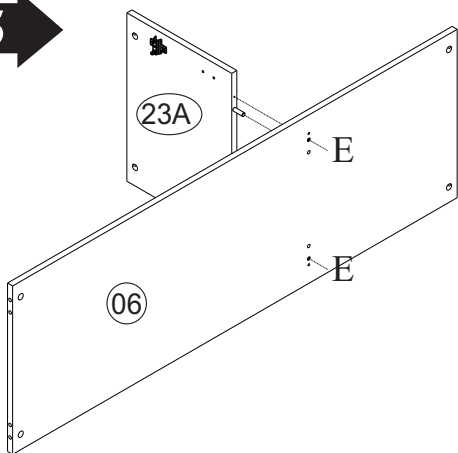

06 →

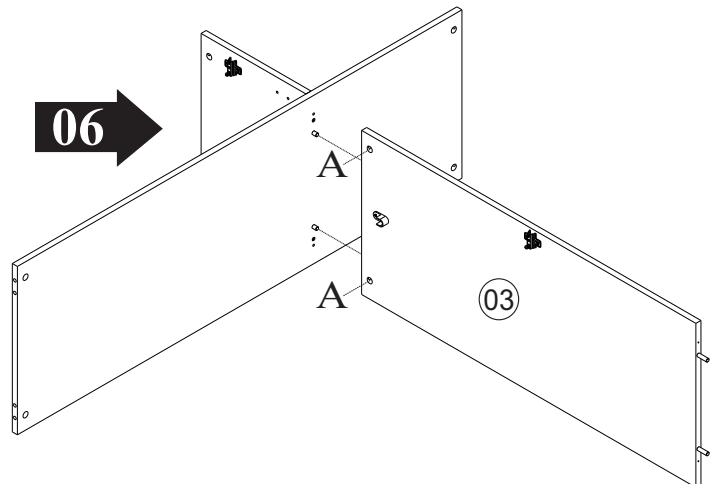

07

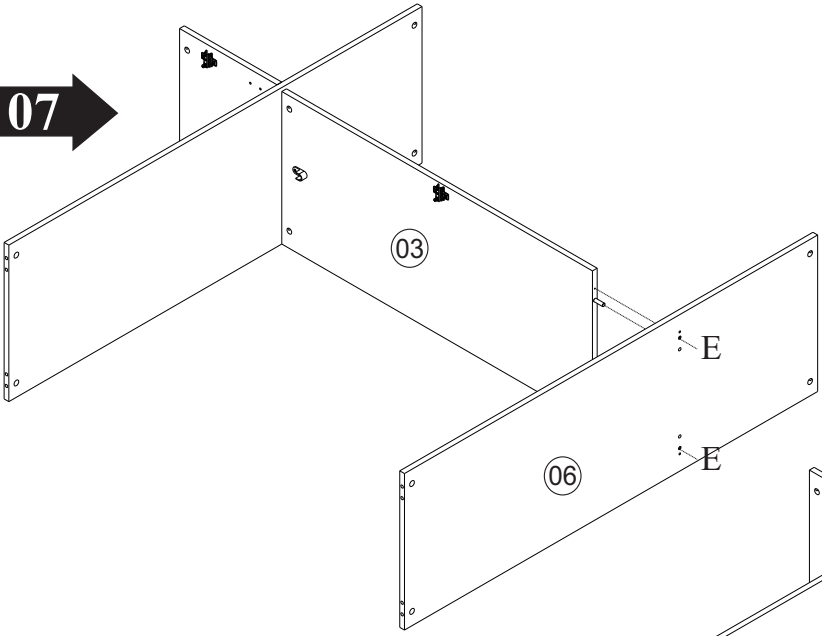

08

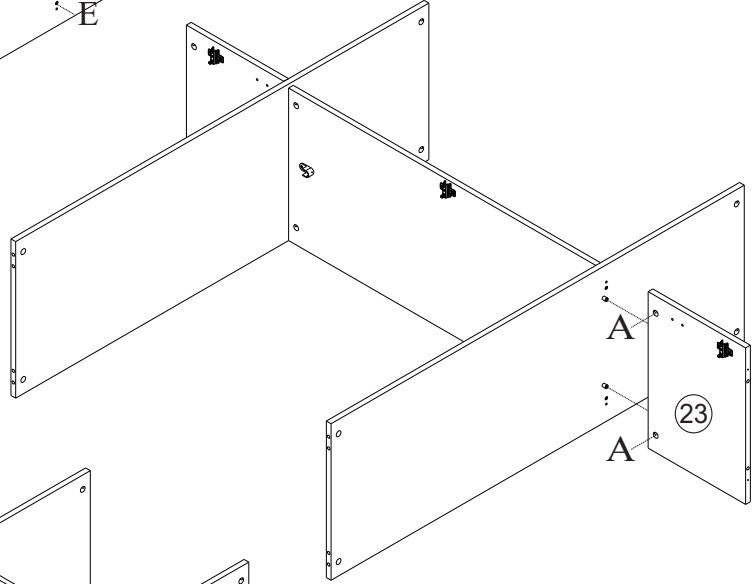

09

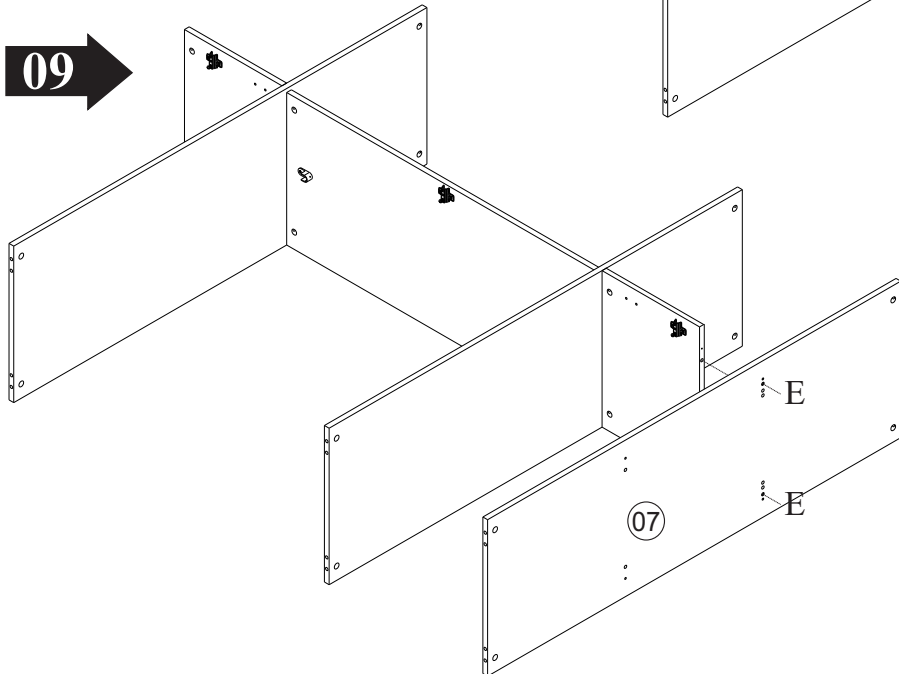

11

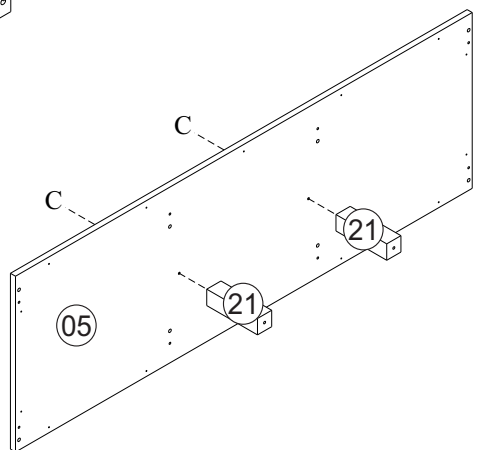

10

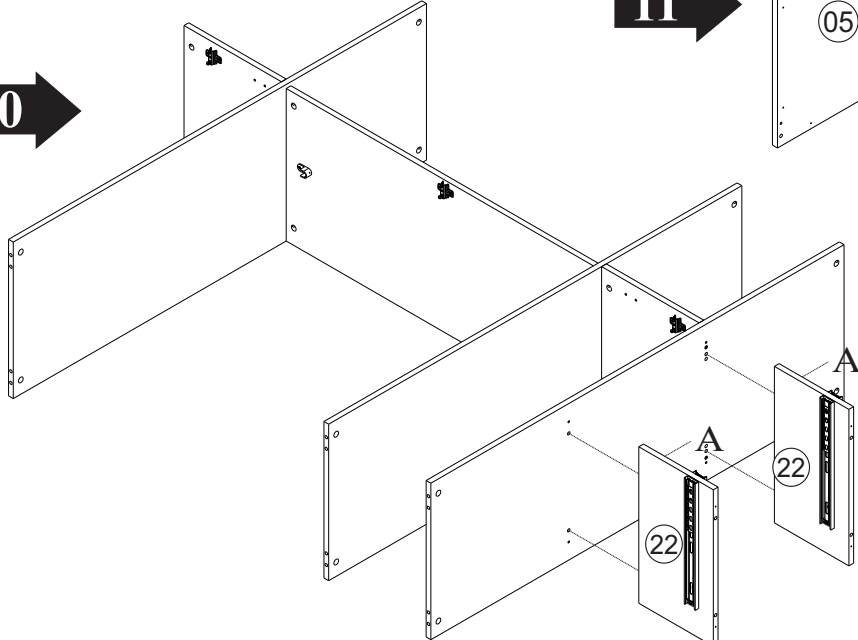

12

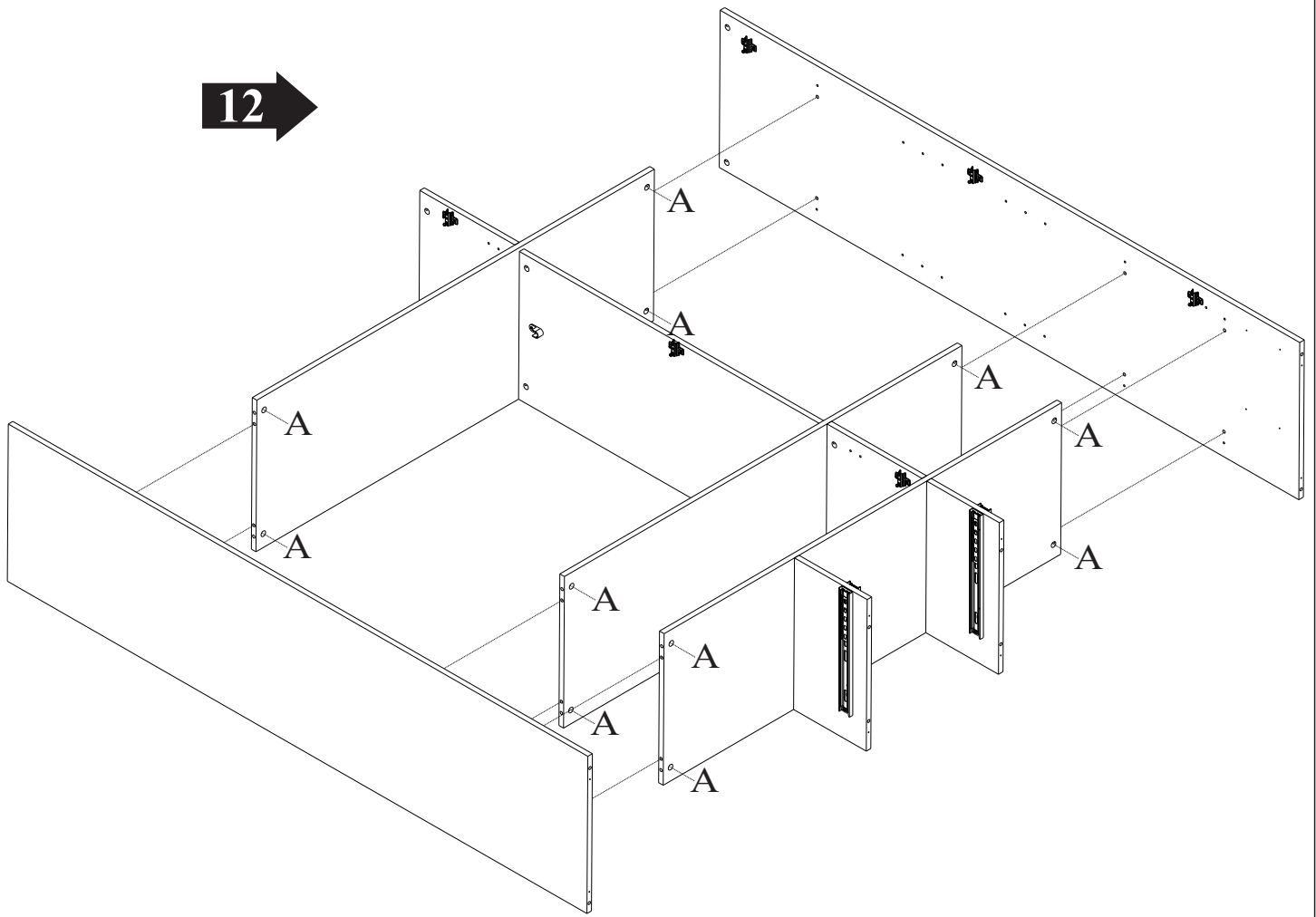

13

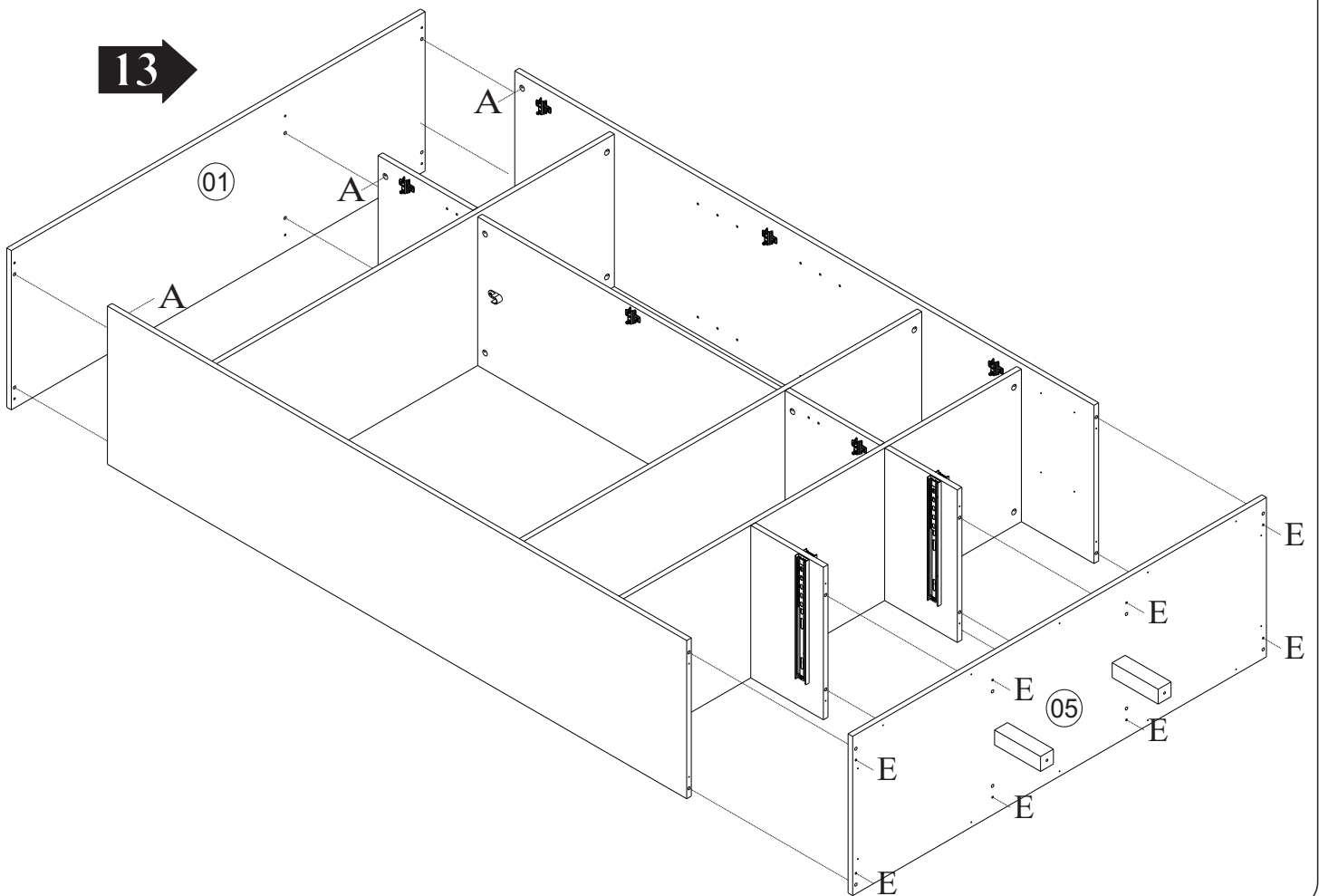

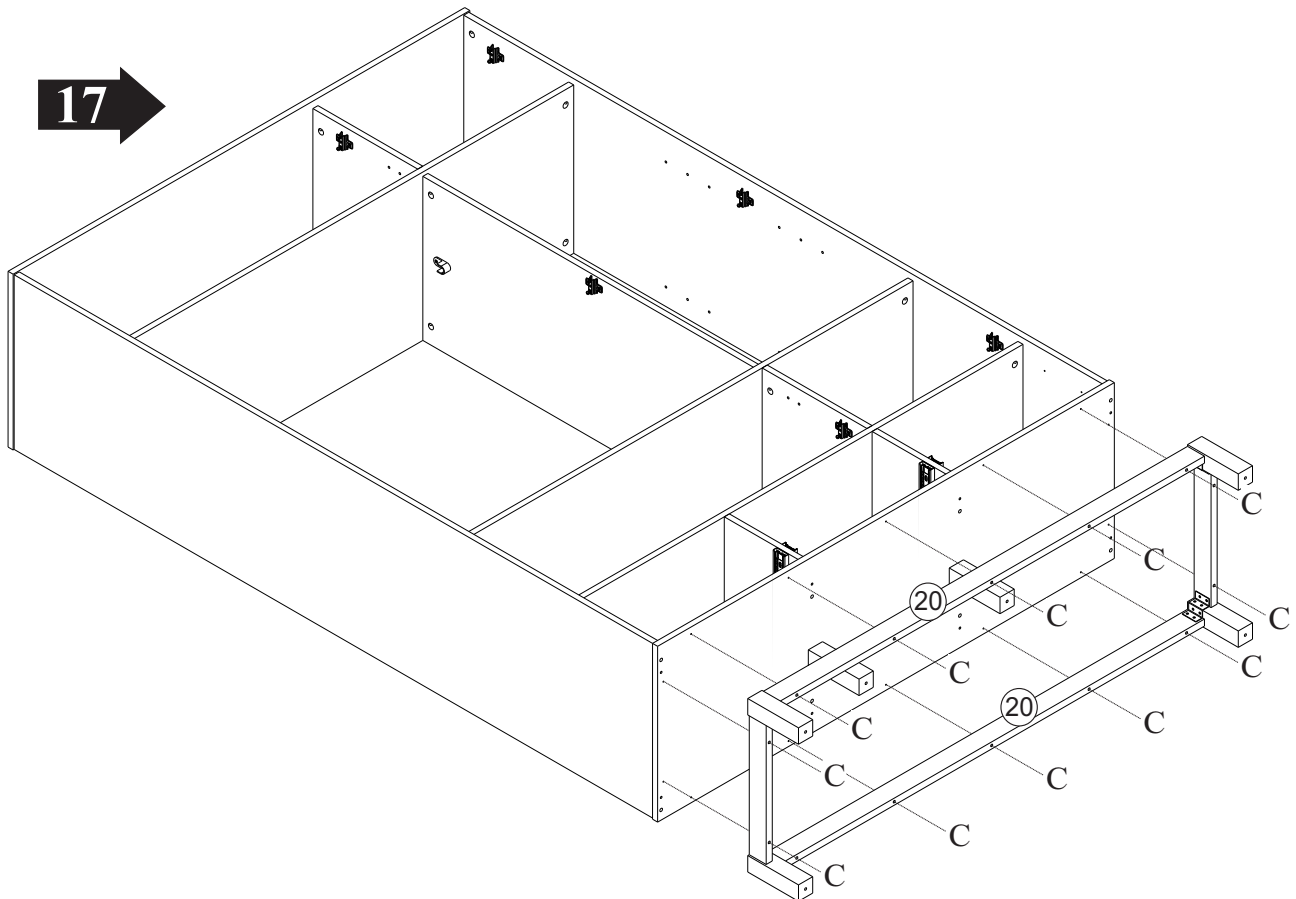
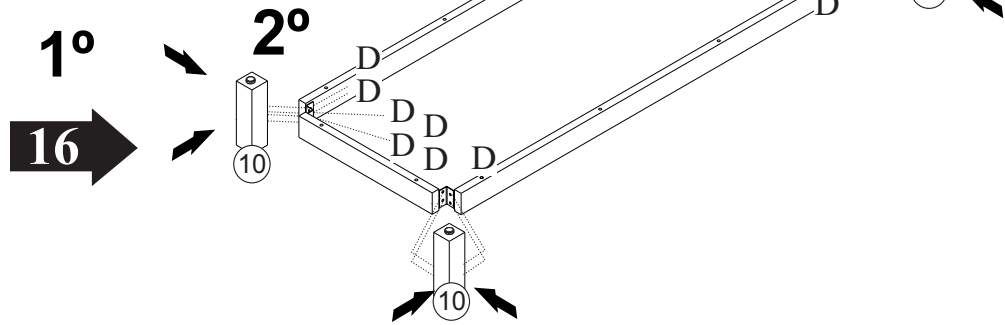
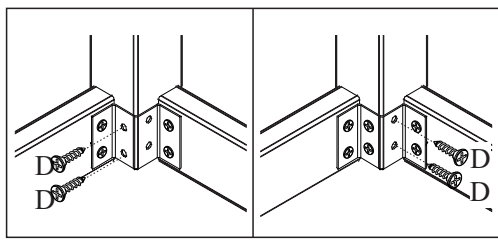
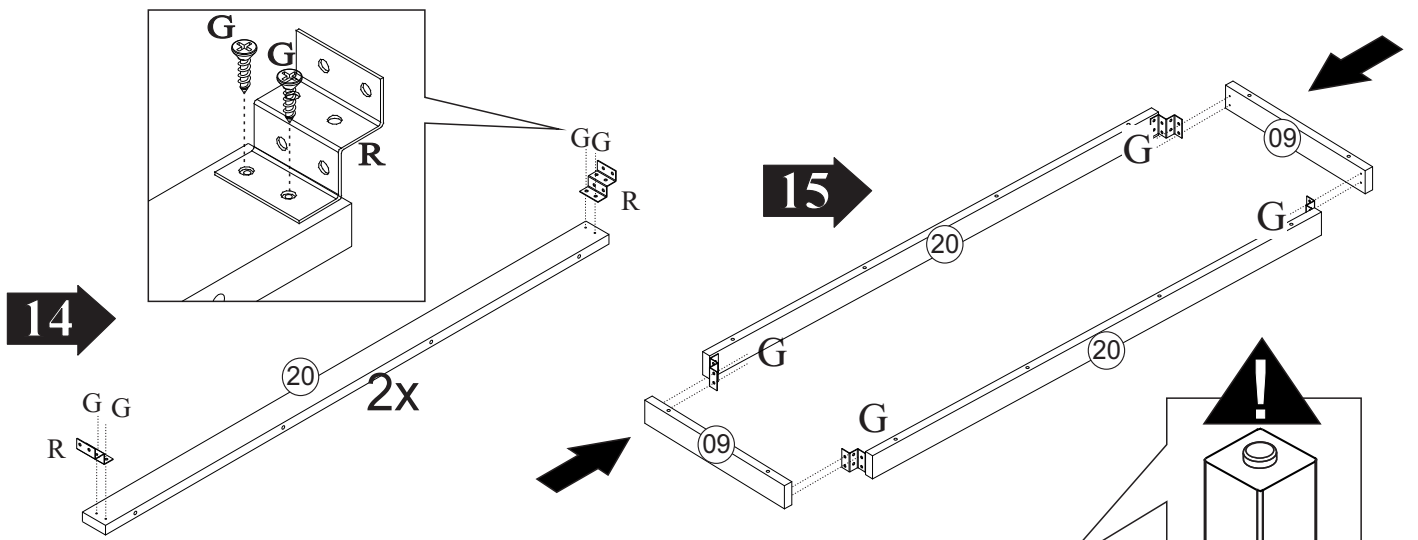

18

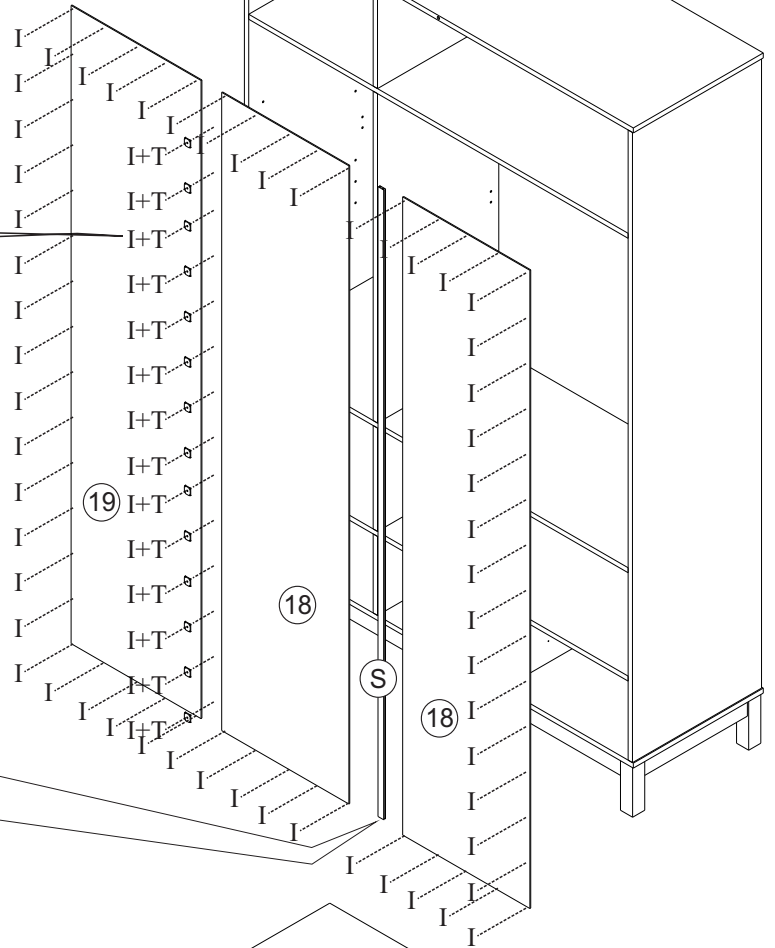
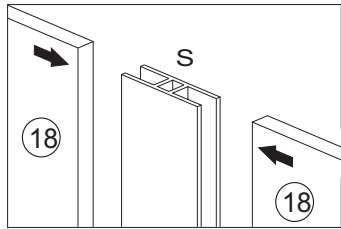
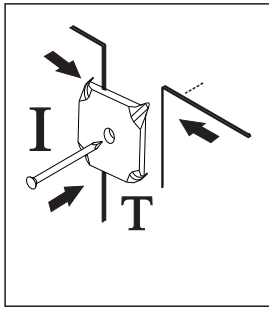

19

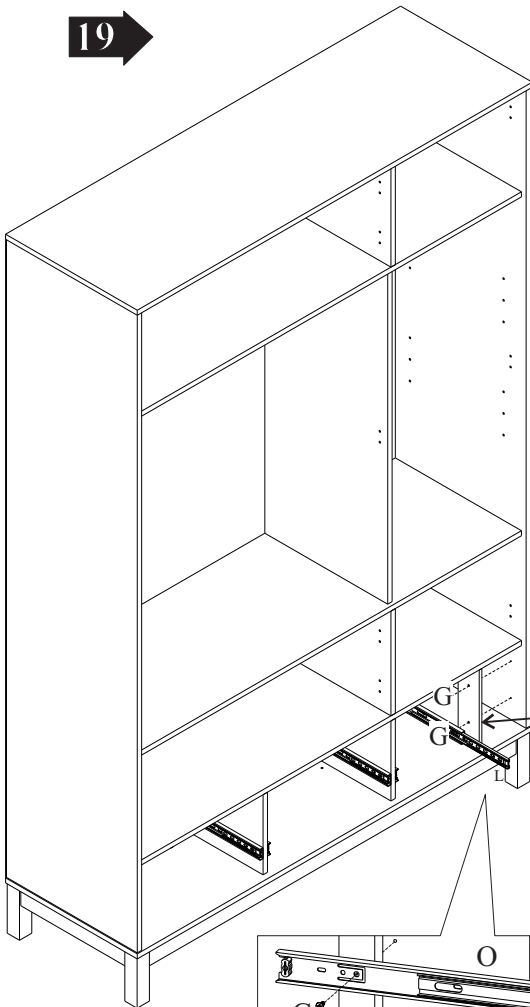

20

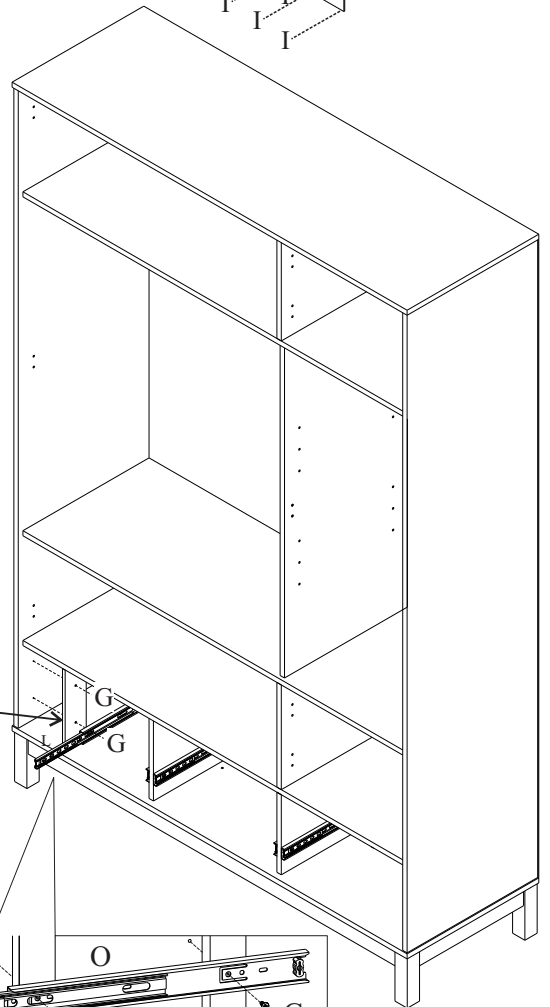

24

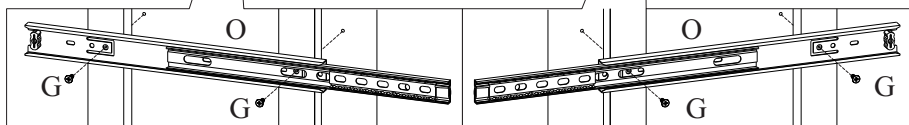

21

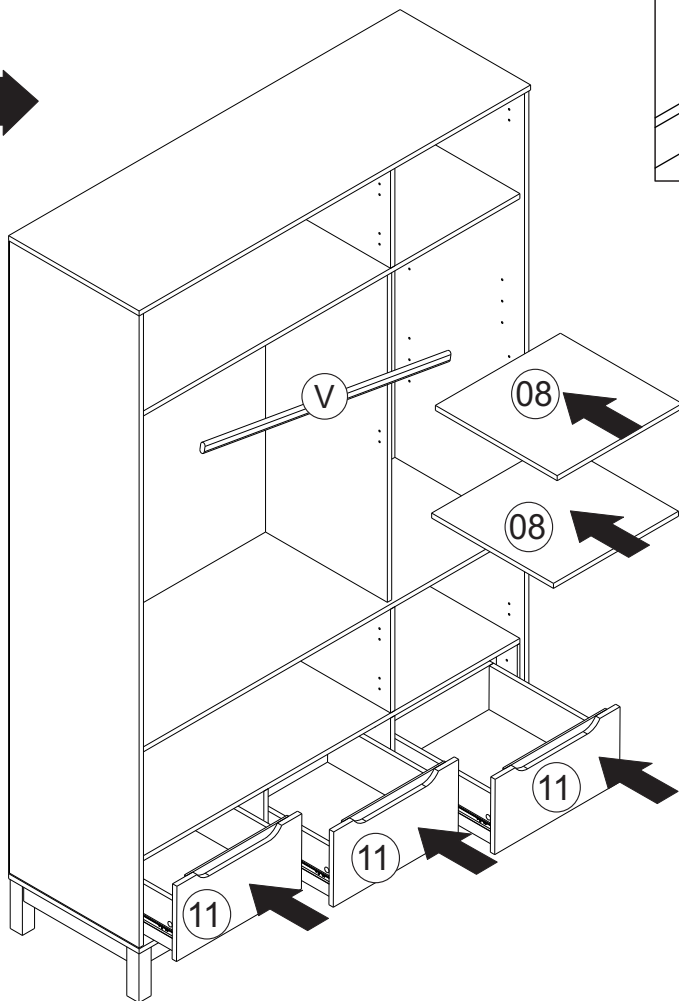

22

