

Ref.: 28440

| | | |
|---|--|----|
| A | | 22 |
| B | | 60 |
| C | | 22 |
| D | | 12 |
| E | | 04 |
| F | | 18 |
| G | | 56 |
| H | | 08 |
| I | | 24 |
| J | | 06 |
| K | | 84 |

| | | | |
|---|--|-------------------|----|
| L | | Ø35 Dobradiça | 08 |
| M | | Calço Super Curva | 08 |
| N | | 3,5x16 Chata | 16 |
| P | | 2019mm | 01 |
| Q | | 3,5x25 Flangeado | 20 |
| T | | | 02 |
| U | | 1120mm | 01 |
| V | | | 08 |
| W | | | 04 |
| X | | | 04 |
| Y | | | 02 |

Utilizar a régua abaixo para medir os componentes.



medidas em mm

| Nº Peça | Nome da Peça | Qtde |
|---------|----------------------------|------|
| 1 | Tampo | 01 |
| 2 | Fundo | 01 |
| 3 | Lateral Direita | 01 |
| 4 | Pé | 04 |
| 5 | Lateral Esquerda | 01 |
| 6 | Divisória Gavetas | 02 |
| 7 | Distanciador de Gavetas | 04 |
| 8 | Porta Direita | 01 |
| 9 | Porta Esquerda | 01 |
| 10 | Prateleira Fixa Maior | 02 |
| 11 | Travessa Maior Base | 02 |
| 12 | Traseiro | 01 |
| 13 | Travessa de Gaveta | 03 |
| 14 | Frente de Gaveta | 03 |
| 15 | Lateral Direita de Gaveta | 03 |
| 16 | Lateral Esquerda de Gaveta | 03 |
| 17 | Traseiro de Gaveta | 03 |
| 18 | Fundo de Gaveta | 03 |
| 19 | Traseira Larga | 01 |
| 20 | Travessa Lateral Base | 02 |

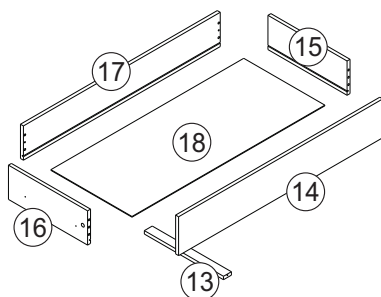

3x

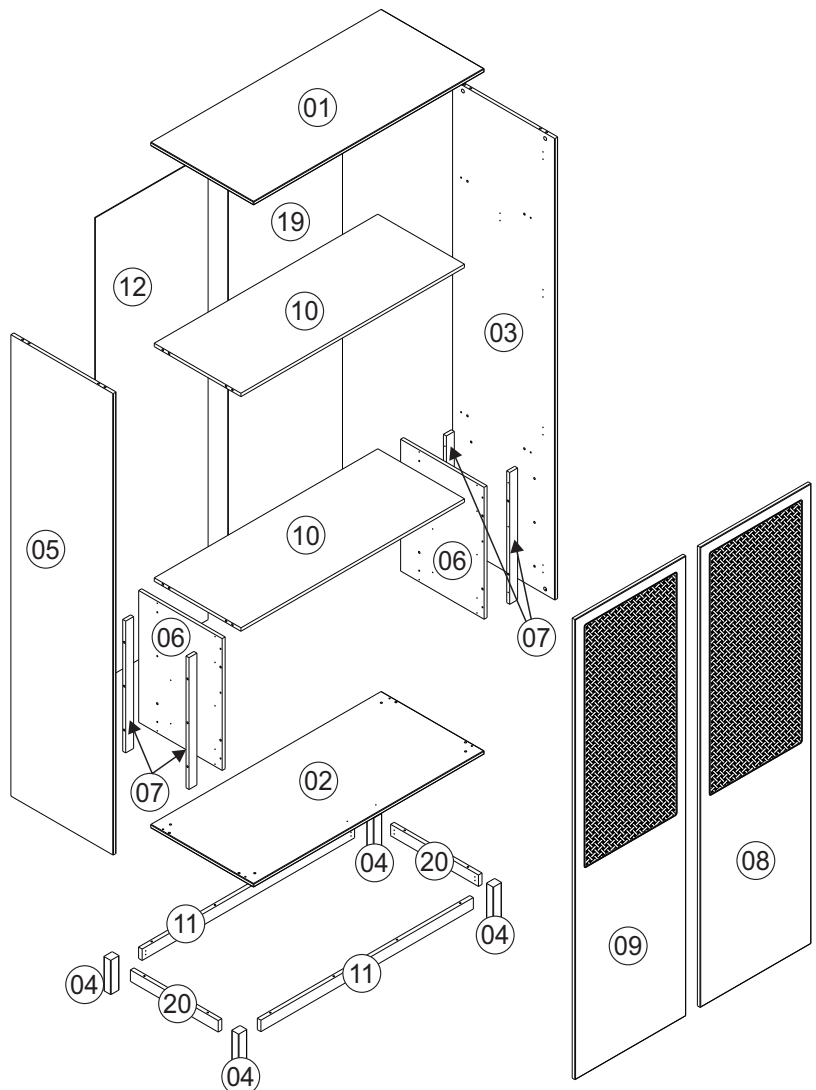

01

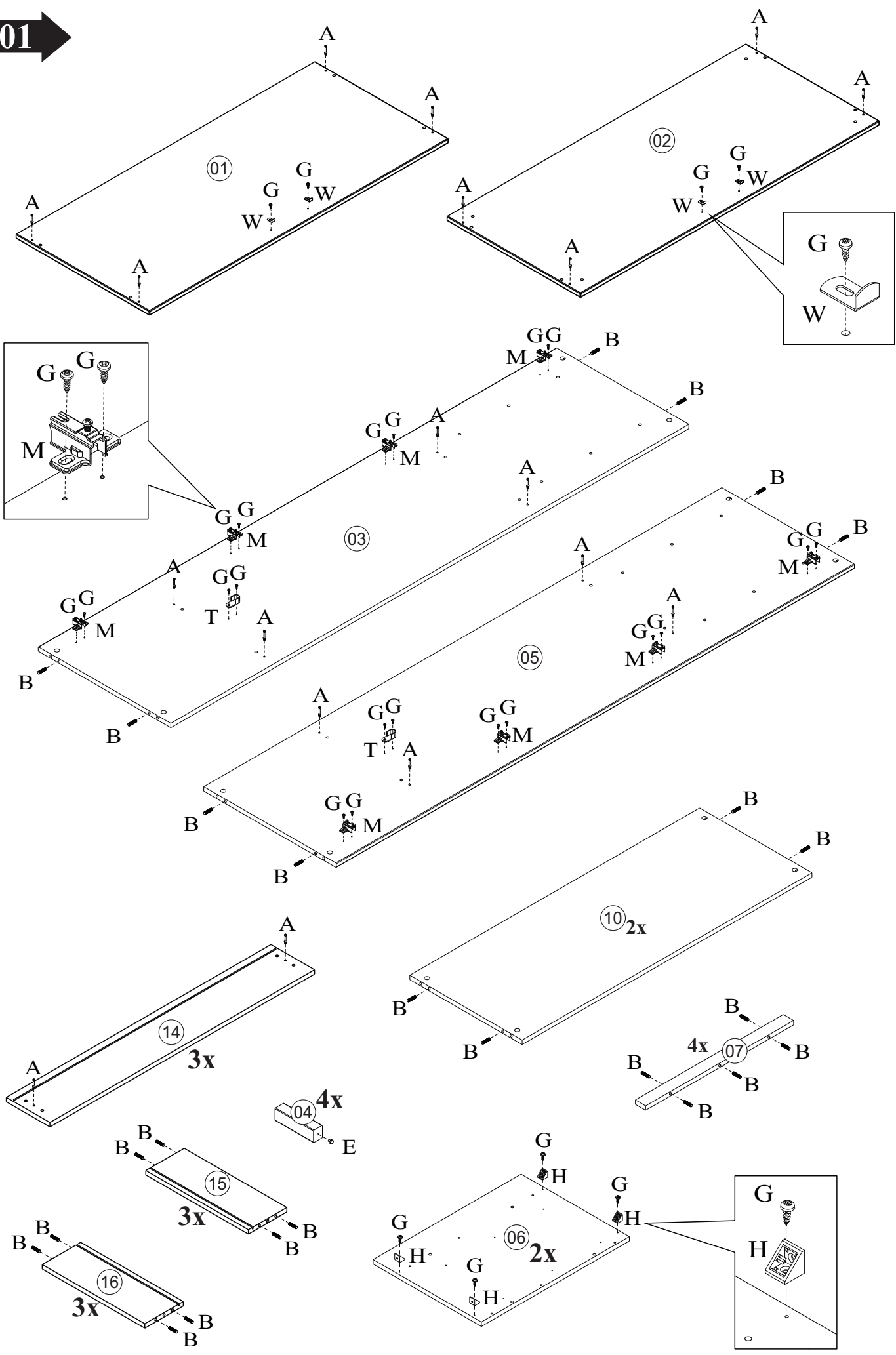

02

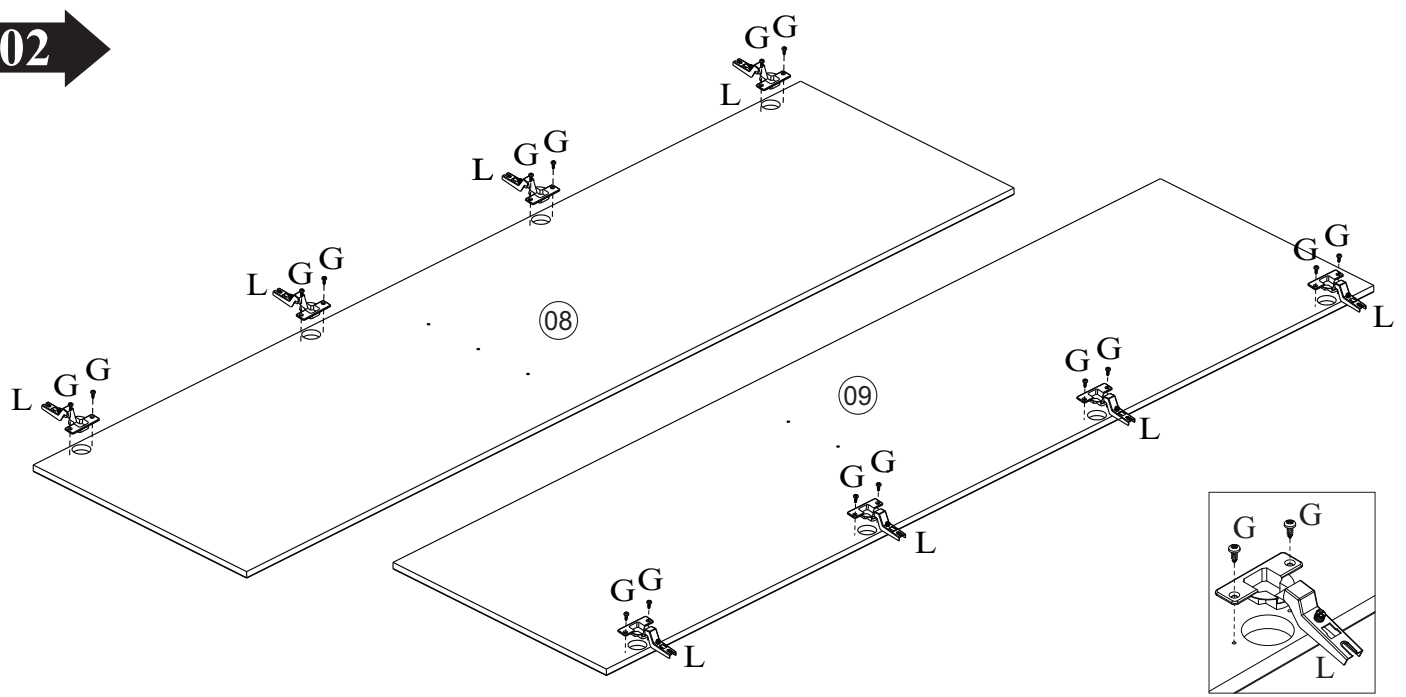

03

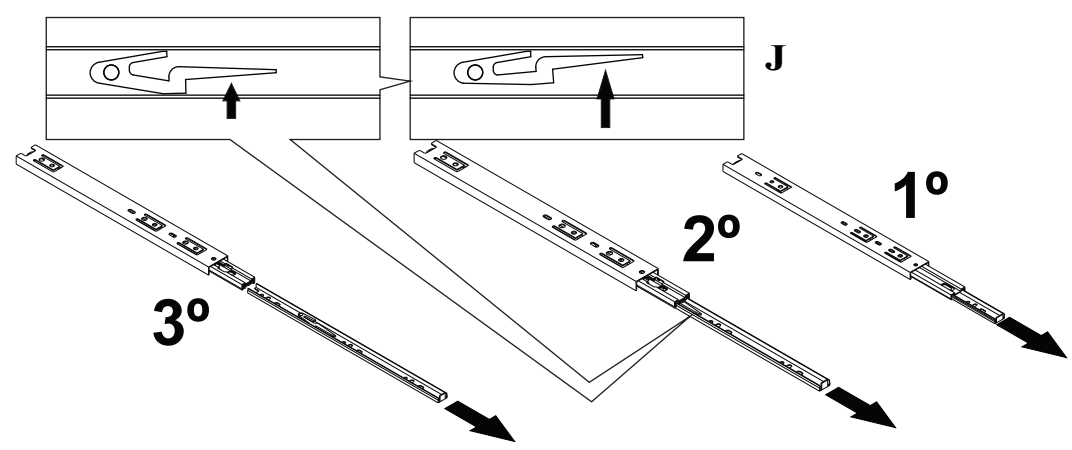

04 3x

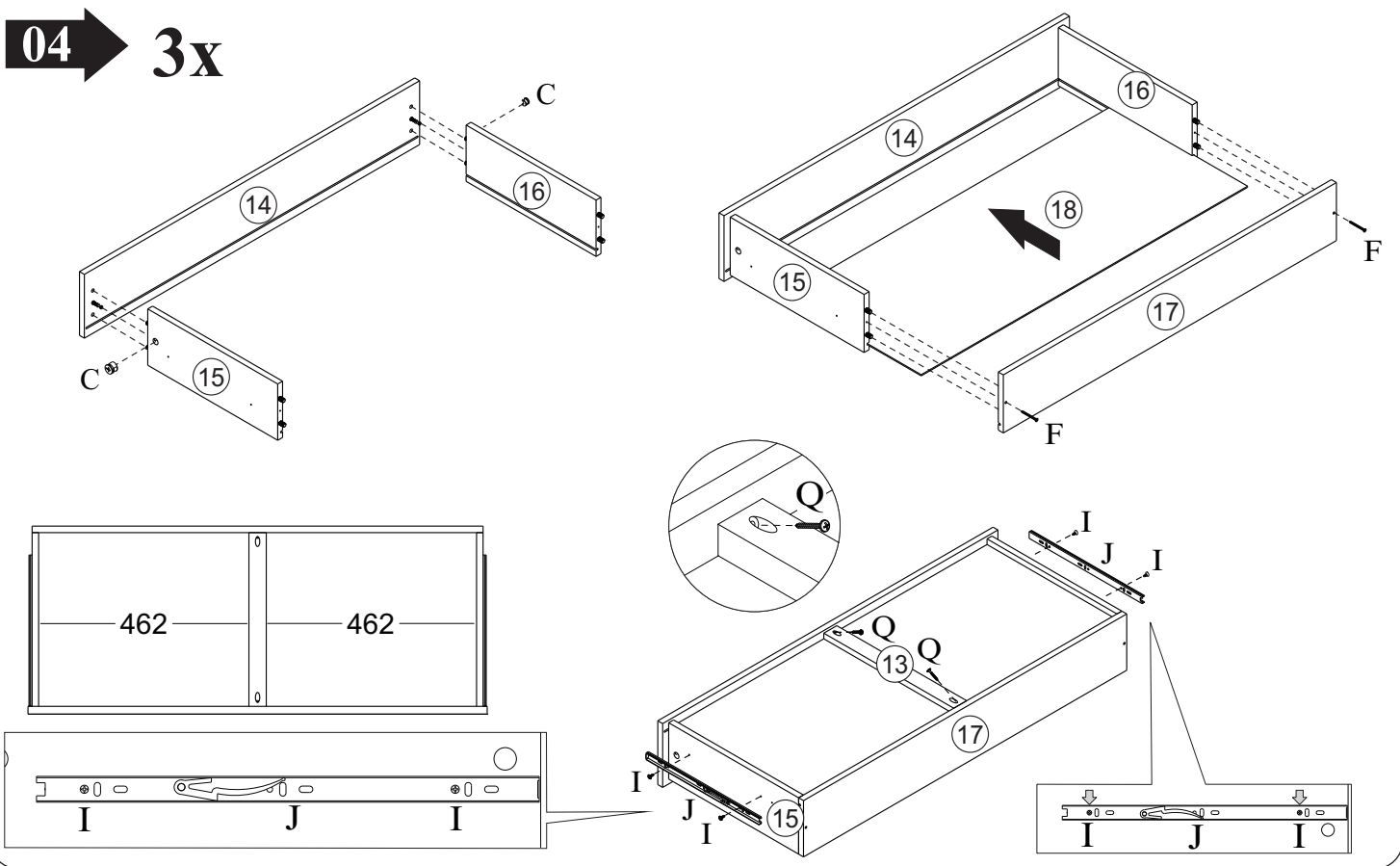

05

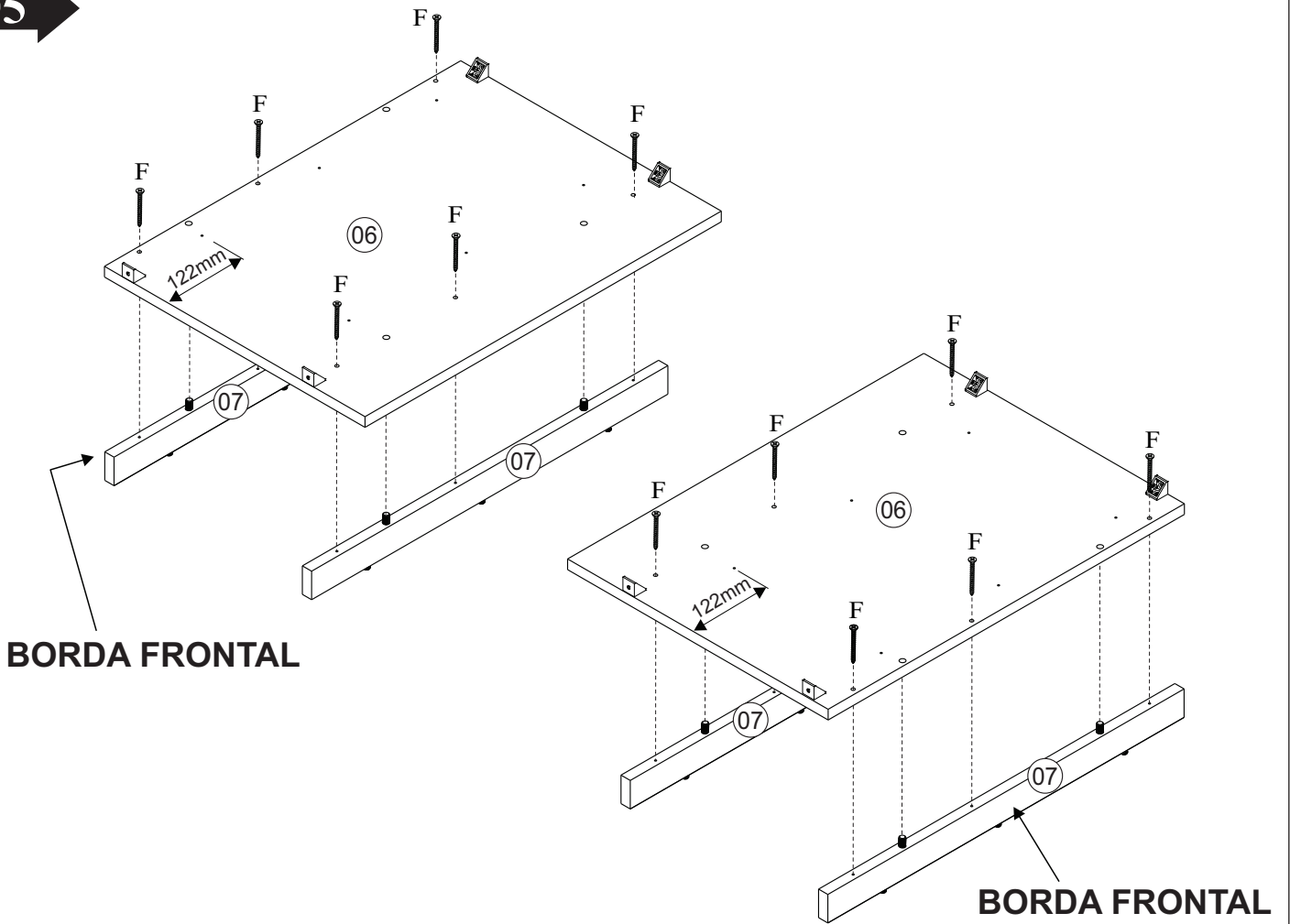

06

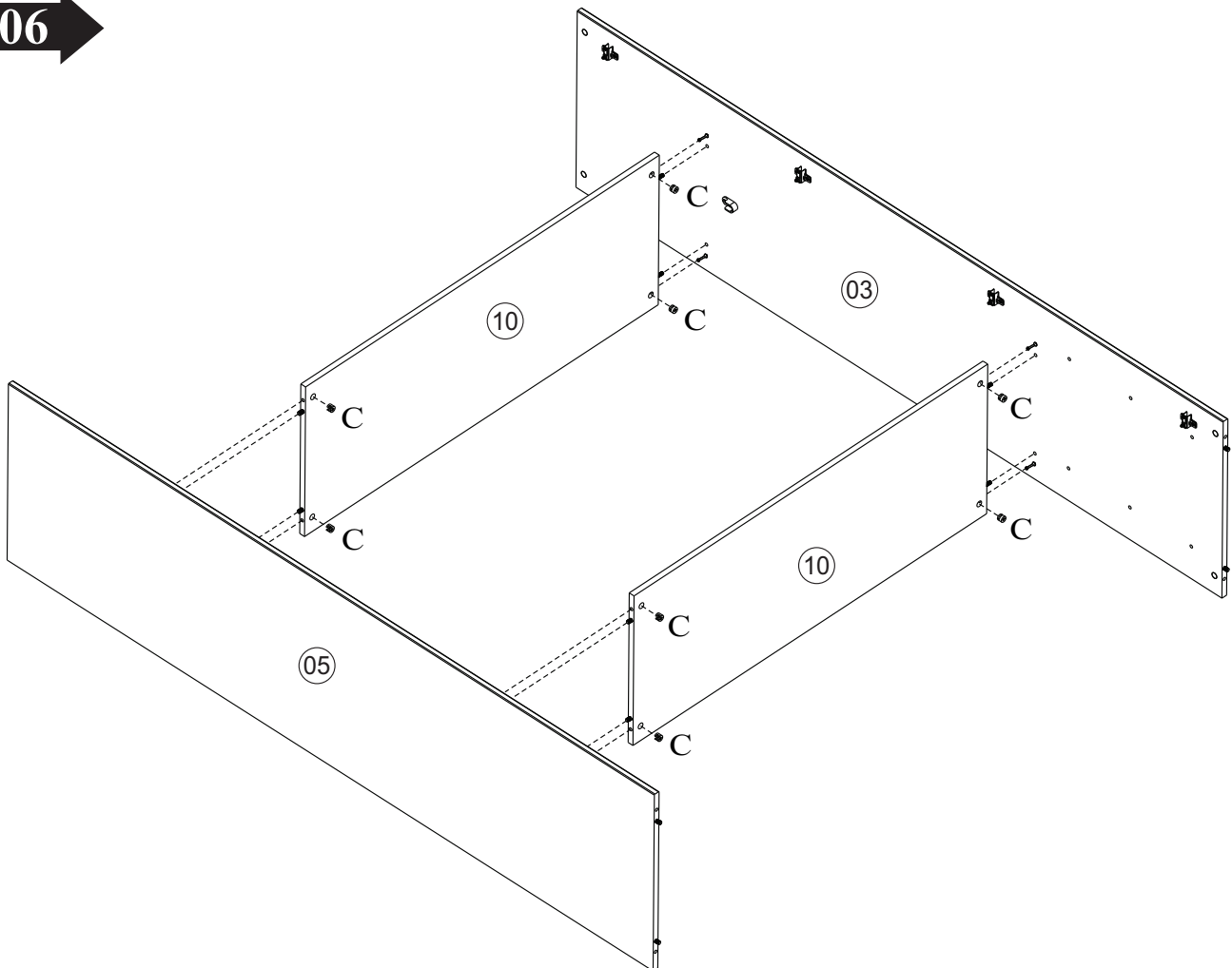

07

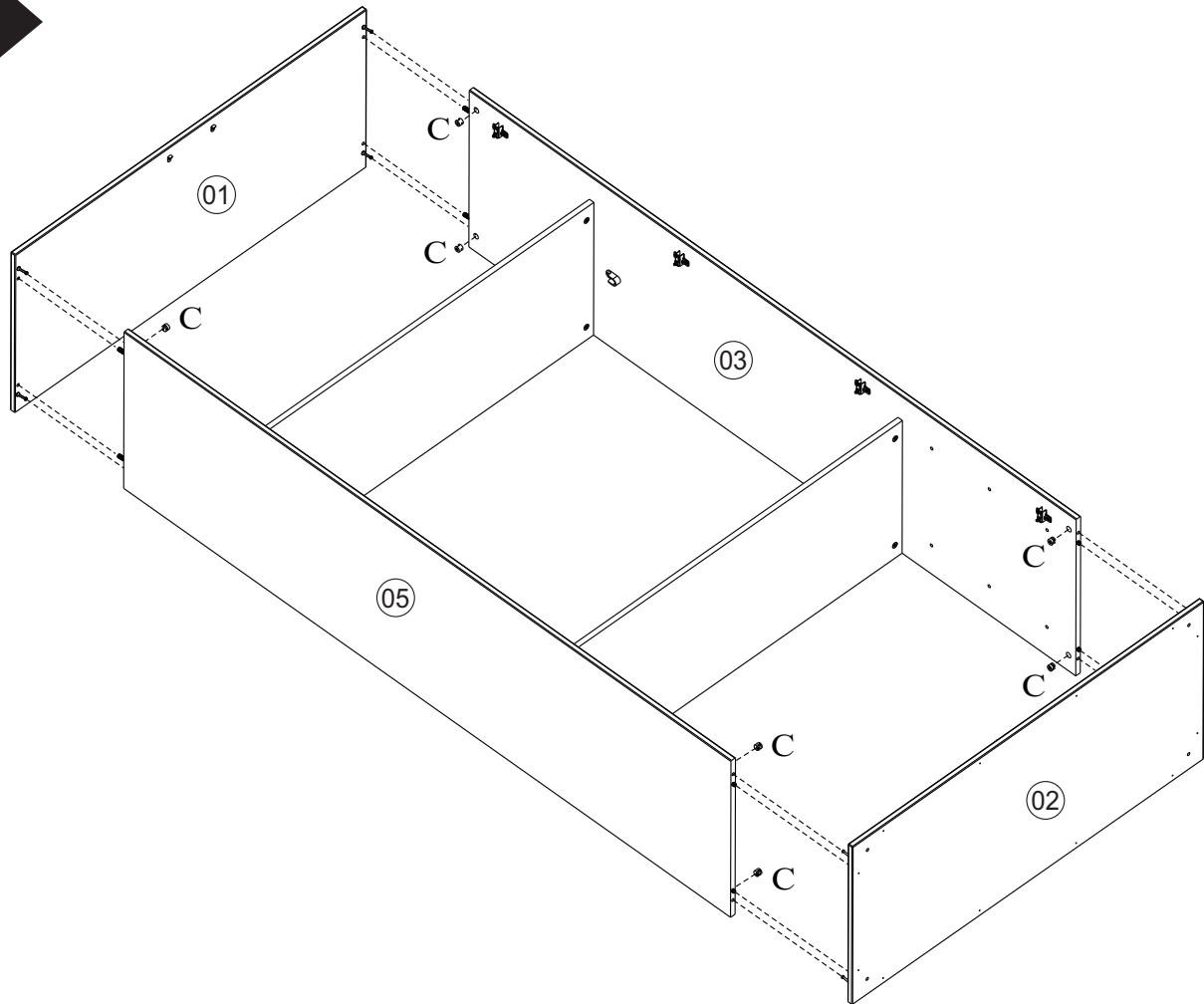

08

2x

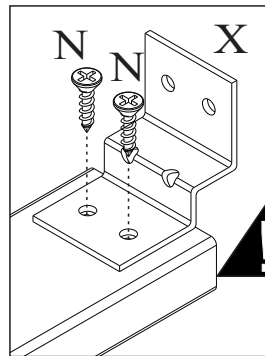
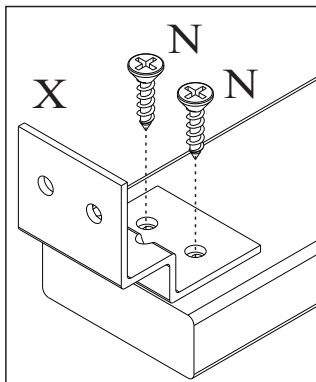

Prestar Atenção
neste passo da
montagem

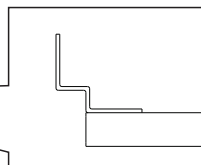
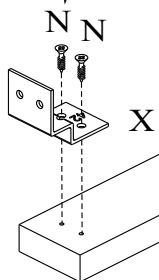
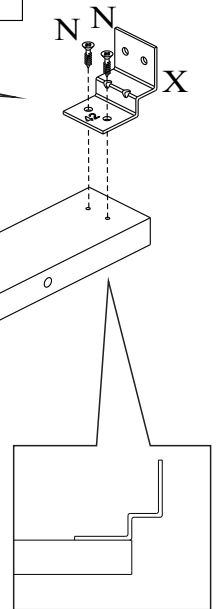

09

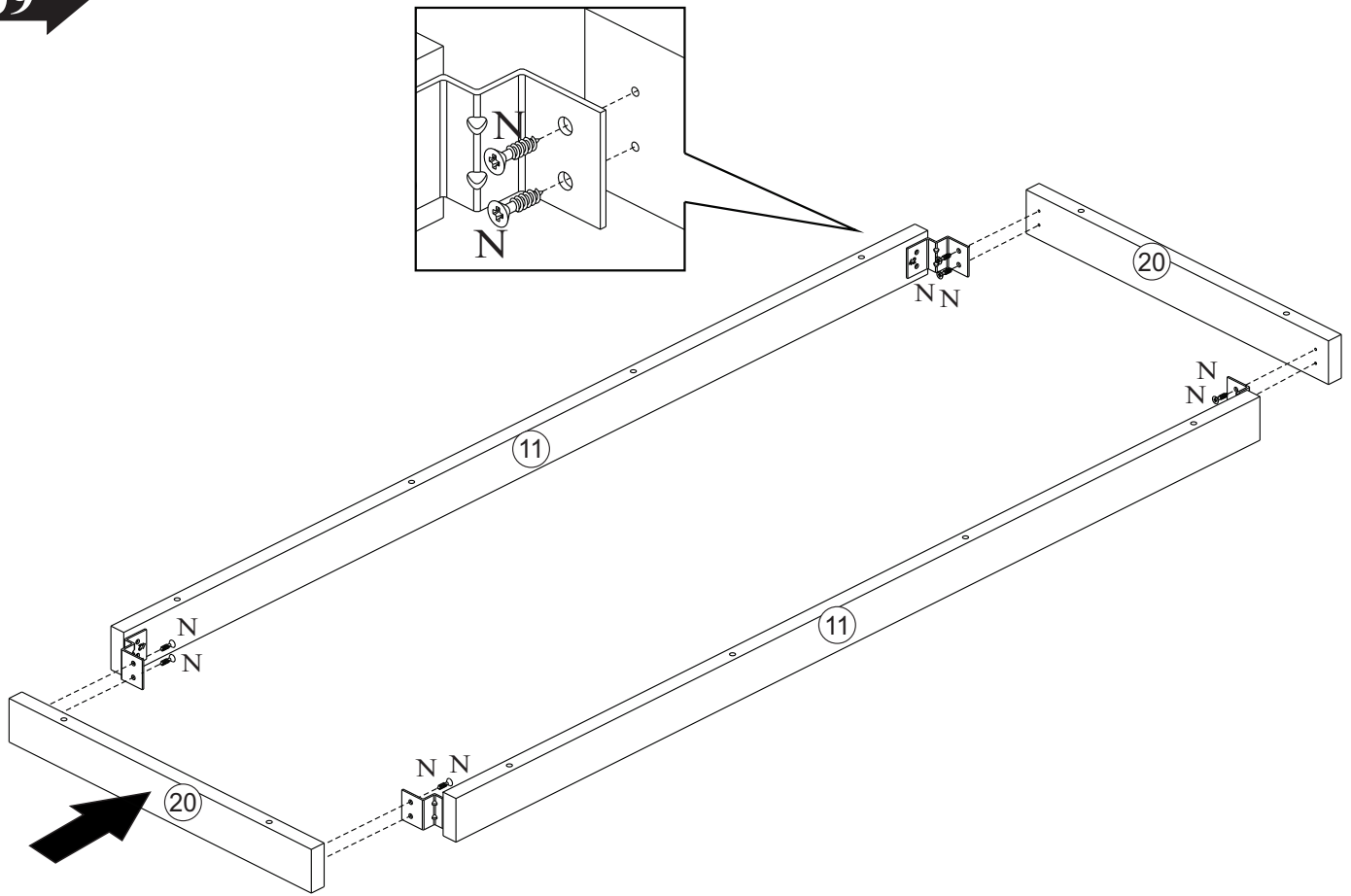

10

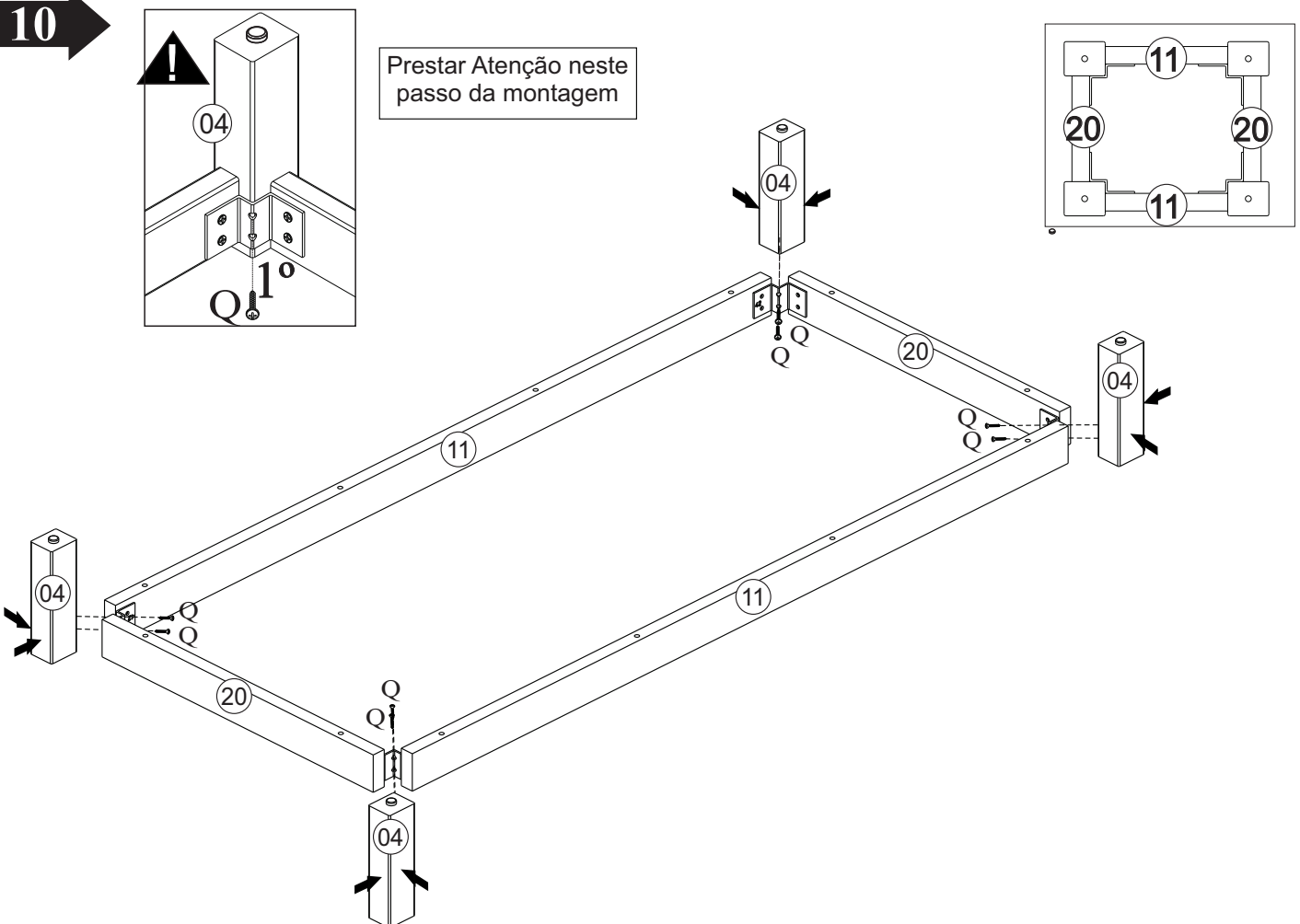

11

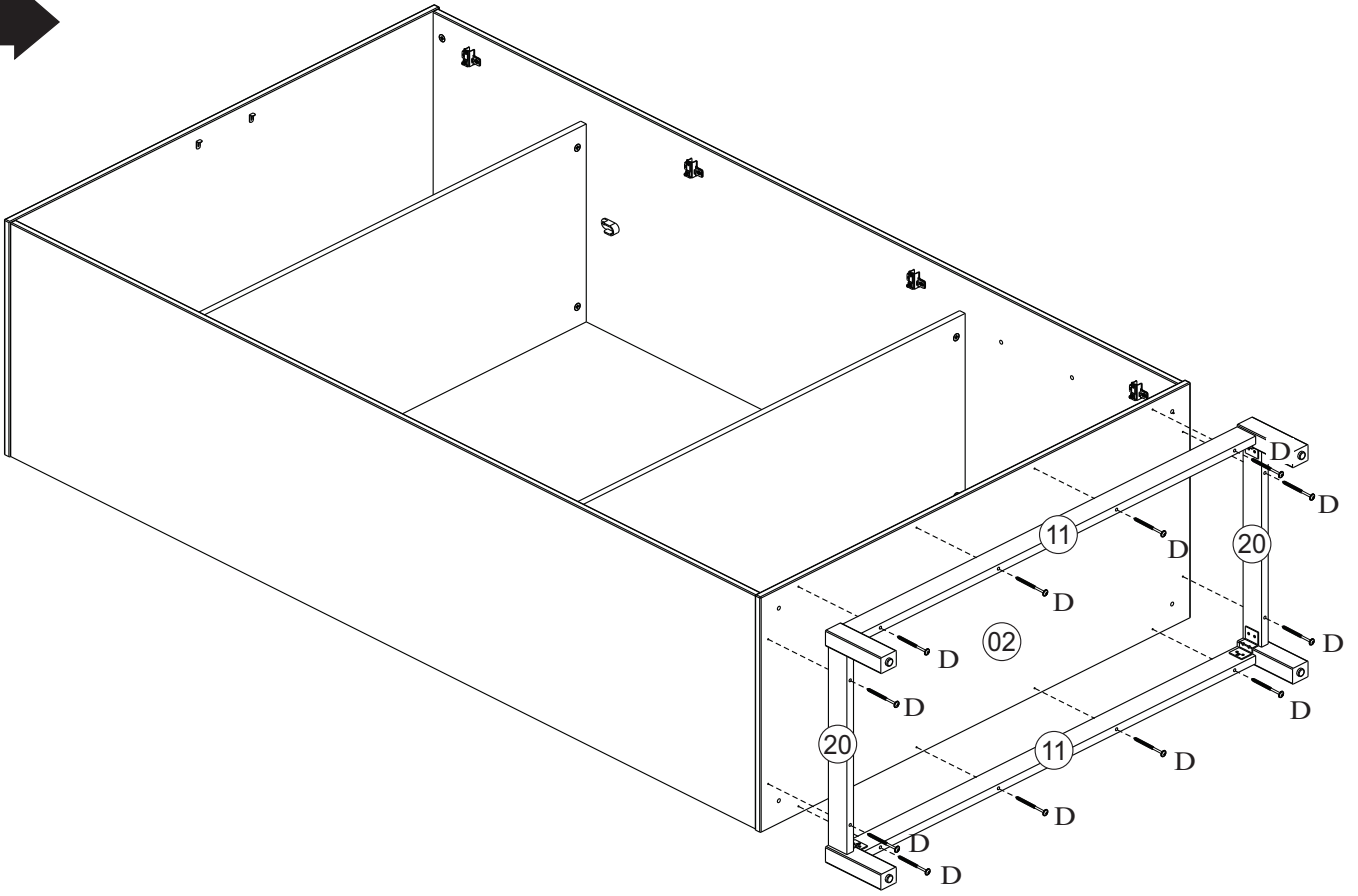

12

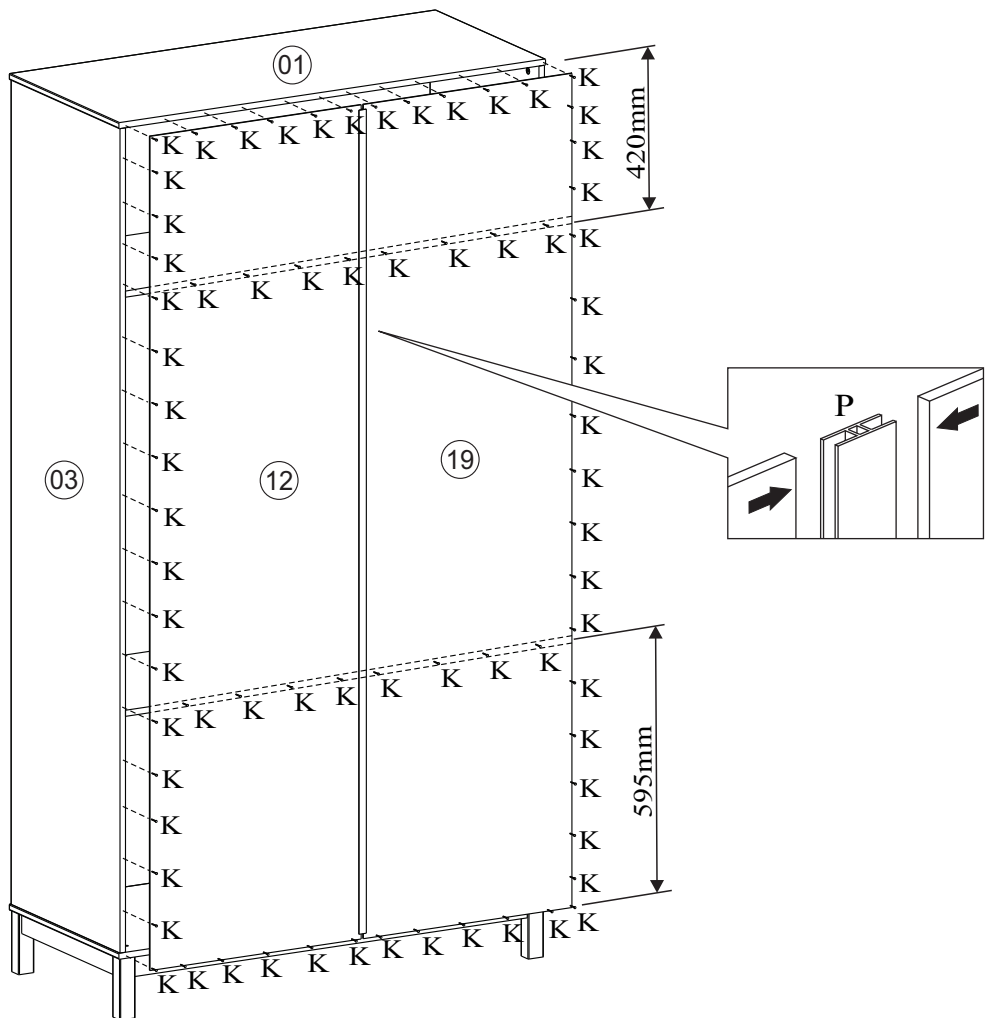

13

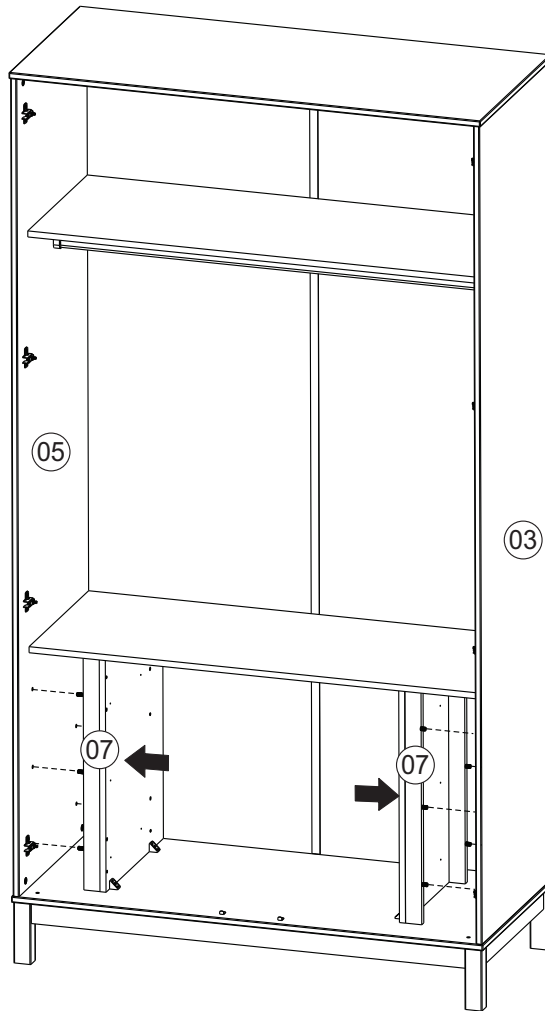

14

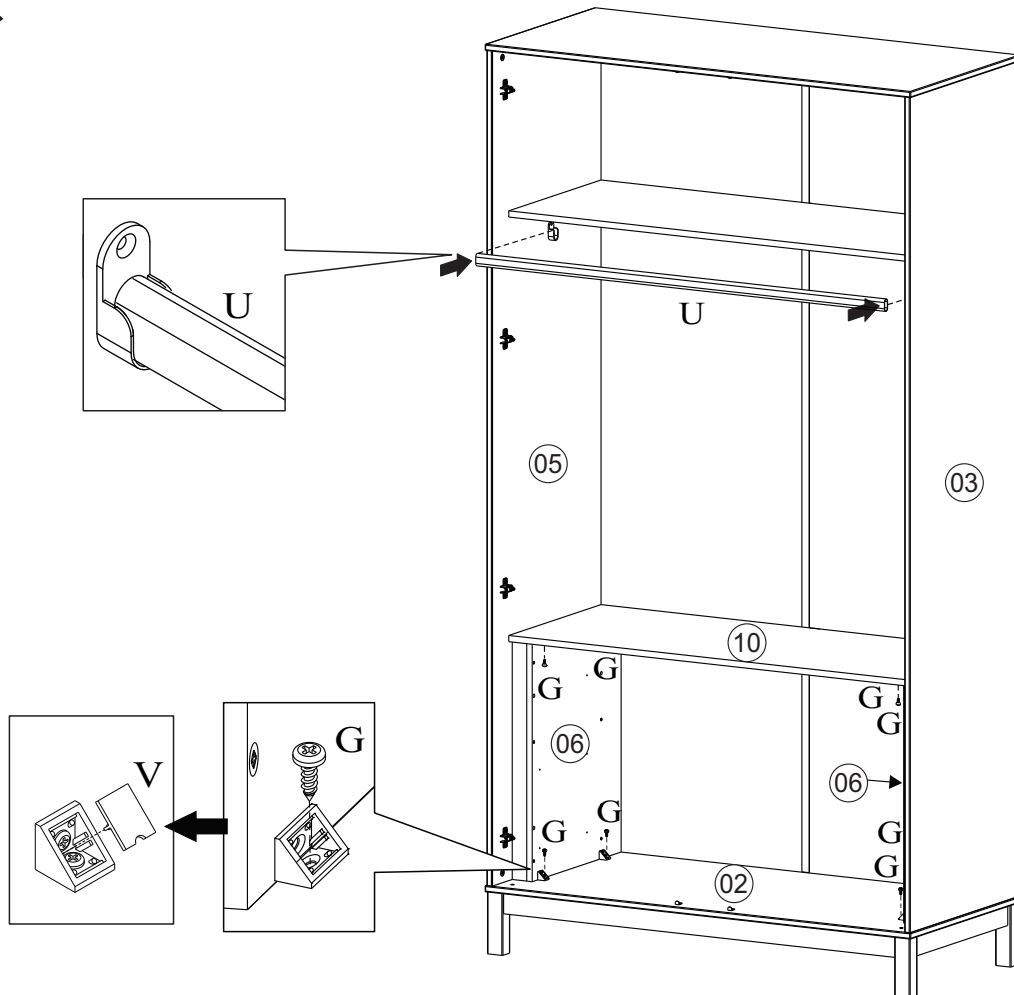

15

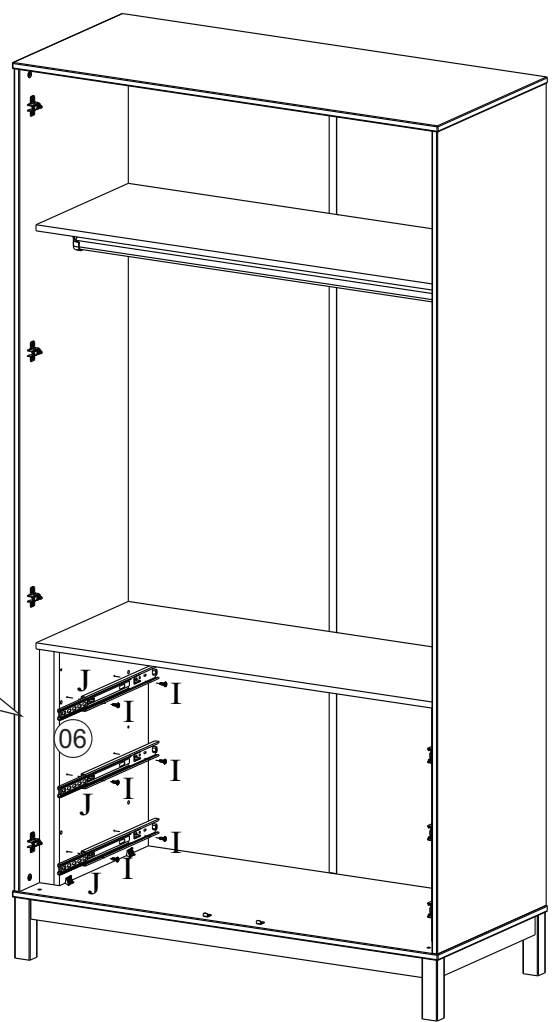
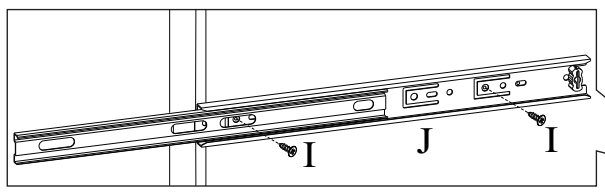

16

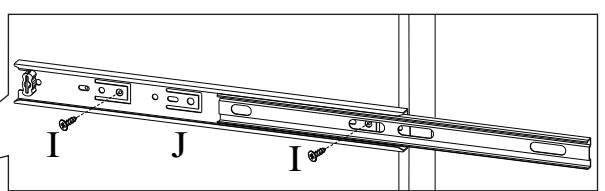
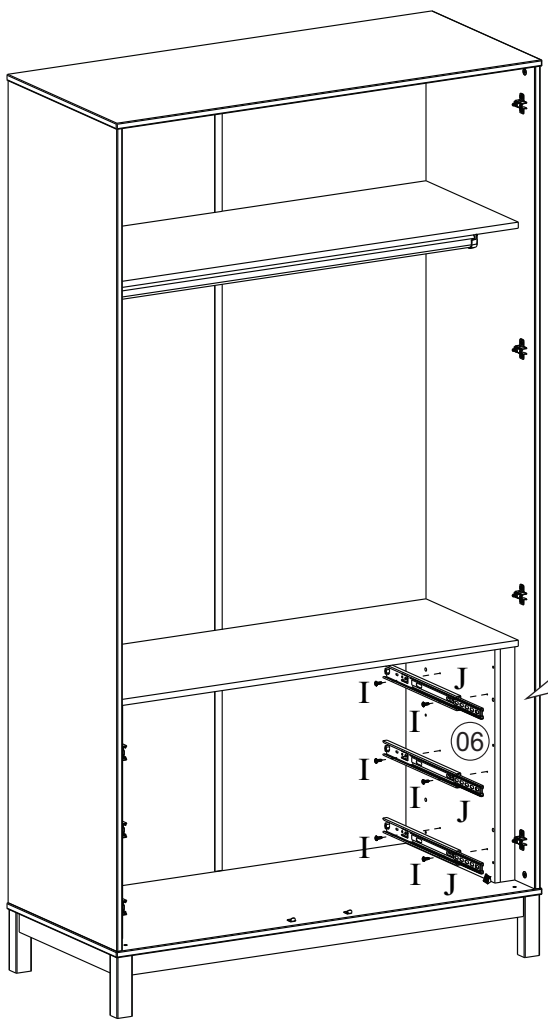

17

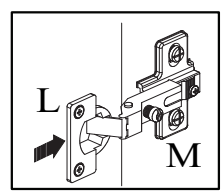
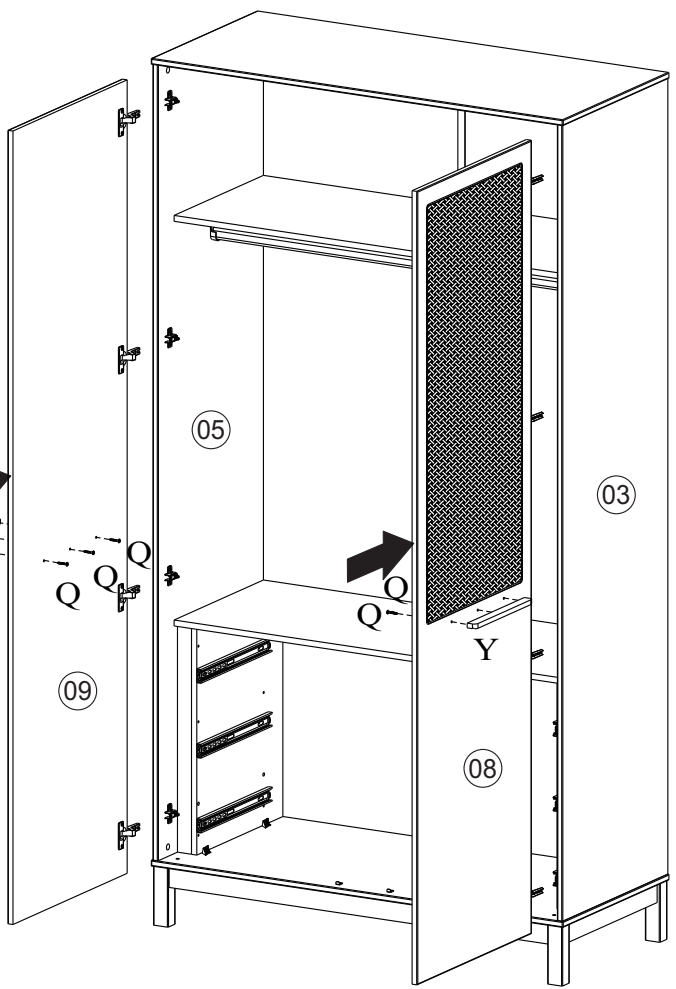
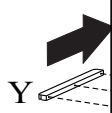
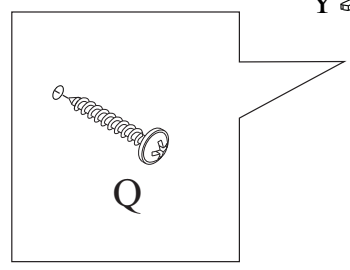

1°

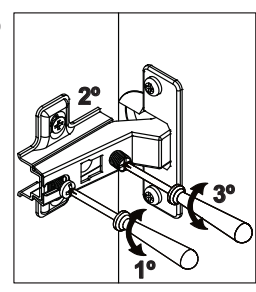

2°

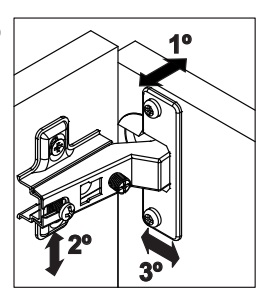

Importante! Fazer os furos para o puxador utilizando broca Ø5mm.

18

